

(12) INTERNATIONAL APPLICATION PUBLISHED UNDER THE PATENT COOPERATION TREATY (PCT)

(19) World Intellectual Property  
Organization  
International Bureau



(43) International Publication Date  
4 March 2004 (04.03.2004)

PCT

(10) International Publication Number  
WO 2004/018824 A2

- (51) International Patent Classification<sup>7</sup>: E21B [US/US]; 19115 Prospect Ridge Lane, Houston, TX 77094 (US). RING, Lev [RU/US]: 14126 Heatherhill Place, Houston, TX 77077 (US).
- (21) International Application Number: PCT/US2003/025677
- (22) International Filing Date: 18 August 2003 (18.08.2003)
- (25) Filing Language: English
- (26) Publication Language: English
- (30) Priority Data: 60/405,610 23 August 2002 (23.08.2002) US
- (71) Applicant (for all designated States except US): ENVENTURE GLOBAL TECHNOLOGY [US/US]: 16200 A Park Row, Houston, TX 77084 (US).
- (72) Inventors: and
- (75) Inventors/Applicants (for US only): SHUSTER, Mark
- (74) Agents: MATTINGLY, Todd et al.; Haynes and Boone, L.L.P., 1000 Louisiana Street, Suite 4300, Houston, TX 77002-5012 (US).
- (81) Designated States (national): AE, AG, AL, AM, AT, AU, AZ, BA, BB, BG, BR, BY, BZ, CA, CH, CN, CO, CR, CU, CZ, DE, DK, DM, DZ, EC, EE, ES, FI, GB, GD, GE, GH, GM, HR, HU, ID, IL, IN, IS, JP, KE, KG, KP, KR, KZ, LC, LK, LR, LS, LT, LU, LV, MA, MD, MG, MK, MN, MW, MX, MZ, NO, NZ, OM, PH, PL, PT, RO, RU, SC, SD, SE, SG, SK, SL, TJ, TM, TN, TR, TT, TZ, UA, UG, US, UZ, VC, VN, YU, ZA, ZM, ZW.
- (84) Designated States (regional): ARIPO patent (GH, GM, KE, LS, MW, MZ, SD, SL, SZ, TZ, UG, ZM, ZW), Eurasian patent (AM, AZ, BY, KG, KZ, MD, RU, TJ, TM), European patent (AT, BE, BG, CH, CY, CZ, DE, DK, EE,

[Continued on next page]

(54) Title: MAGNETIC IMPULSE APPLIED SLEEVE METHOD OF FORMING A WELLBORE CASING

(57) Abstract: A method of forming a wellbore casing within a borehole that traverses a subterranean formation includes the steps of assembling a tubular liner by coupling a threaded portion of a first tubular member to a threaded portion of a second tubular member and coupling a tubular sleeve to the threaded portions of the first and second tubular members. The method further includes positioning the wellbore casing within the borehole and radially expanding and plastically deforming the wellbore casing assembly within the borehole. The step of coupling the tubular sleeve through the threaded portions of the first and second tubular members includes applying impulsive magnetic energy to the tubular sleeve.

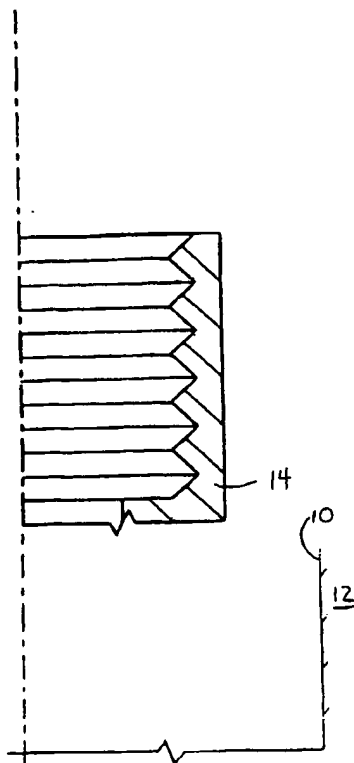

WO 2004/018824 A2





ES, FI, FR, GB, GR, HU, IE, IT, LU, MC, NL, PT, RO,  
SE, SI, SK, TR). OAPI patent (BF, BJ, CF, CG, CI, CM,  
GA, GN, GQ, GW, ML, MR, NE, SN, TD, TG).

**Published:**

— without international search report and to be republished  
upon receipt of that report

**Declaration under Rule 4.17:**

— of inventorship (Rule 4.17(iv)) for US only

For two-letter codes and other abbreviations, refer to the "Guidance Notes on Codes and Abbreviations" appearing at the beginning of each regular issue of the PCT Gazette.

**MAGNETIC IMPULSE APPLIED SLEEVE METHOD OF FORMING A WELLBORE  
CASING**

**Cross Reference To Related Applications**

**[0001]** The present application claims the benefit of the filing dates of (1) U.S. provisional patent application serial no. 60/405,610, attorney docket no 25791.119, filed on 8/23/2002, the disclosure of which is incorporated herein by reference.

**[0002]** The present application is related to the following: (1) U.S. patent application serial no. 09/454,139, attorney docket no. 25791.03.02, filed on 12/3/1999, (2) U.S. patent application serial no. 09/510,913, attorney docket no. 25791.7.02, filed on 2/23/2000, (3) U.S. patent application serial no. 09/502,350, attorney docket no. 25791.8.02, filed on 2/10/2000, (4) U.S. patent no. 6,328,113, (5) U.S. patent application serial no. 09/523,460, attorney docket no. 25791.11.02, filed on 3/10/2000, (6) U.S. patent application serial no. 09/512,895, attorney docket no. 25791.12.02, filed on 2/24/2000, (7) U.S. patent application serial no. 09/511,941, attorney docket no. 25791.16.02, filed on 2/24/2000, (8) U.S. patent application serial no. 09/588,946, attorney docket no. 25791.17.02, filed on 6/7/2000, (9) U.S. patent application serial no. 09/559,122, attorney docket no. 25791.23.02, filed on 4/26/2000, (10) PCT patent application serial no. PCT/US00/18635, attorney docket no. 25791.25.02, filed on 7/9/2000, (11) U.S. provisional patent application serial no. 60/162,671, attorney docket no. 25791.27, filed on 11/1/1999, (12) U.S. provisional patent application serial no. 60/154,047, attorney docket no. 25791.29, filed on 9/16/1999, (13) U.S. provisional patent application serial no. 60/159,082, attorney docket no. 25791.34, filed on 10/12/1999, (14) U.S. provisional patent application serial no. 60/159,039, attorney docket no. 25791.36, filed on 10/12/1999, (15) U.S. provisional patent application serial no. 60/159,033, attorney docket no. 25791.37, filed on 10/12/1999, (16) U.S. provisional patent application serial no. 60/212,359, attorney docket no. 25791.38, filed on 6/19/2000, (17) U.S. provisional patent application serial no. 60/165,228, attorney docket no. 25791.39, filed on 11/12/1999, (18) U.S. provisional patent application serial no. 60/221,443, attorney docket no. 25791.45, filed on 7/28/2000, (19) U.S. provisional patent application serial no. 60/221,645, attorney docket no. 25791.46, filed on 7/28/2000, (20) U.S. provisional patent application serial no. 60/233,638, attorney docket no. 25791.47, filed on 9/18/2000, (21) U.S. provisional patent application serial no. 60/237,334, attorney docket no. 25791.48, filed on 10/2/2000, (22) U.S. provisional patent application serial no. 60/270,007, attorney docket no. 25791.50, filed on 2/20/2001, (23) U.S. provisional patent application serial no. 60/262,434, attorney docket no. 25791.51, filed on 1/17/2001, (24) U.S. provisional patent application serial no. 60/259,486, attorney docket no. 25791.52, filed on 1/3/2001, (25) U.S. provisional patent application serial no. 60/303,740, attorney docket no. 25791.61, filed on 7/6/2001, (26) U.S. provisional patent application serial no. 60/313,453, attorney docket no. 25791.59, filed on 8/20/2001, (27) U.S. provisional patent application serial no. 60/317,985, attorney docket no. 25791.67, filed on 9/6/2001, (28) U.S. provisional patent

application serial no. 60/3318,386, attorney docket no. 25791.67.02, filed on 9/10/2001, (29) U.S. utility patent application serial no. 09/969,922, attorney docket no. 25791.69, filed on 10/3/2001, (30) U.S. utility patent application serial no. 10/016,467, attorney docket no. 25791.70, filed on 12/10/2001; (31) U.S. provisional patent application serial no. 60/343,674, attorney docket no. 25791.68, filed on 12/27/2001; (32) U.S. provisional patent application serial no. 60/346,309, attorney docket no 25791.92, filed on 1/7/2002; (33) U.S. provisional patent application serial no. 60/372,048, attorney docket no. 25791.93, filed on 4/12/2002; (34) U.S. provisional patent application serial no. 60/380,147, attorney docket no. 25791.104, filed on 5/6/2002; (35) U.S. provisional patent application serial no. 60/387,486, attorney docket no. 25791.107, filed on 6/10/2002; (36) U.S. provisional patent application serial no. 60/387,961, attorney docket no. 25791.108, filed on 6/12/2002; (37) U.S. provisional patent application serial no. 60/391,703, attorney docket no. 25791.90, filed on 6/26/2002; (38) U.S. provisional patent application serial no. 60/397,284, attorney docket no. 25791.106, filed on 7/19/2002, and (39) U.S. provisional patent application serial no. 60/405,394, filed on 8/23/03, the disclosures of which are incorporated herein by reference.

#### **Background of the Invention**

**[0003]** This invention relates generally to oil and gas exploration, and in particular to forming and repairing wellbore casings to facilitate oil and gas exploration.

**[0004]** Conventionally, when a wellbore is created, a number of casings are installed in the borehole to prevent collapse of the borehole wall and to prevent undesired outflow of drilling fluid into the formation or inflow of fluid from the formation into the borehole. The borehole is drilled in intervals whereby a casing which is to be installed in a lower borehole interval is lowered through a previously installed casing of an upper borehole interval. As a consequence of this procedure the casing of the lower interval is of smaller diameter than the casing of the upper interval. Thus, the casings are in a nested arrangement with casing diameters decreasing in downward direction. Cement annuli are provided between the outer surfaces of the casings and the borehole wall to seal the casings from the borehole wall. As a consequence of this nested arrangement a relatively large borehole diameter is required at the upper part of the wellbore. Such a large borehole diameter involves increased costs due to heavy casing handling equipment, large drill bits and increased volumes of drilling fluid and drill cuttings. Moreover, increased drilling rig time is involved due to required cement pumping, cement hardening, required equipment changes due to large variations in hole diameters drilled in the course of the well, and the large volume of cuttings drilled and removed.

**[0005]** During oil exploration, a wellbore typically traverses a number of zones within a subterranean formation. Wellbore casings are then formed in the wellbore by radially expanding and plastically deforming tubular members that are coupled to one another by threaded connections. Existing methods for radially expanding and plastically deforming tubular members coupled to one another by threaded connections are not always reliable, and do not always produce satisfactory results.

In particular, the threaded connections can be damaged during the radial expansion process. Furthermore, the threaded connections between adjacent tubular members, whether radially expanded or not, are typically not sufficiently coupled to permit the transmission of energy through the tubular members from the surface to the downhole location.

**[0006]** The present invention is directed to overcoming one or more of the limitations of the existing procedures for forming new sections of casing in a wellbore.

#### Summary of the Invention

**[0007]** According to one aspect of the present invention, a method of forming a wellbore casing within a borehole that traverses a subterranean formation is provided that includes externally applied tubular sleeve for improved sealing a wellbore casing joints.

**[0008]** According to another aspect of the present invention, a method of forming a wellbore casing within a borehole that traverses a subterranean formation is provided that includes magnetic impulse method for externally applying a tubular sleeve for improved sealing of wellbore casing joints.

**[0009]** According to another aspect of the present invention, a method of forming a wellbore casing within a borehole that traverses a subterranean formation is provided that includes expanding joined tubular members such as joined wellbore casings with a tubular sleeve externally applied to the surfaces of the joined wellbore casing and overlapping the joint thereby maintaining an improved seal of the wellbore casing joints after expansion.

**[00010]** According to another aspect of the present invention, a method of improving the seal of tubular members that are connected and then expanded is provided, that includes using a magnetic impulse method for externally applying a tubular sleeve to the joint between the tubular members prior to expanding the connected tubular members.

**[00011]** According to another aspect of the present invention, an improved method of connecting wellbore casing tubular member is provided that includes forming raised ring portions to enhance surface contact stress in the coupling connection and subsequently applying inward radial force with a tubular sleeve imposed by magnetic impulse method for improved sealing of the joints between the tubular members.

#### Brief Description of the Drawings

**[0010]** FIG. 1 is a fragmentary cross-sectional schematic illustration of a first tubular member, such a first wellbore casing, for placement within a borehole that traverses a subterranean formation.

**[0011]** FIG. 2 is a fragmentary cross-sectional schematic illustration of the first tubular member, such as the first wellbore casing as in Fig. 1 and an aligned second tubular member, such as a second wellbore casing in position for coupling together and for placing the first and second tubular members, such as the depicted wellbore casings within a borehole.

**[0012]** FIG. 3 is a fragmentary cross-sectional schematic illustration of first and second wellbore casings of Fig. 2 after overlapping coupling as with the first female threads and second male threads

providing a substantially continuous wellbore that may be radially expanded and plastically deformed at the overlapping portions of the first and second wellbore casings.

**[0013]** FIG. 4 is a fragmentary cross-sectional schematic illustration of the coupling joint of Fig. 3 after placing a tubular sleeve axially aligned with the first and second wellbore casings, and overlappingly positioned at the joint formed by coupling the first and second wellbore casings.

**[0014]** FIG. 5 is a fragmentary cross-sectional schematic illustration of the first and second wellbore casings and of the tubular sleeve of Fig. 4 and further schematically depicting one illustration of a magnetic impulse apparatus positioned at the tubular sleeve for externally applying the tubular sleeve for improved sealing of the joint formed by coupling the wellbore casings together.

**[0015]** FIG. 6 is a fragmentary cross-sectional schematic illustration of the apparatus of Fig. 5, after applying magnetic impulse force to the tubular sleeve for improved sealing of the joint formed by coupling the first and second wellbore casings of Fig. 5.

**[0016]** FIG. 7 is a fragmentary cross-sectional schematic illustration of a joint of a first and second tubular member, such as a first and second wellbore casing, having a tubular sleeve externally applied to the adjacent external surfaces of the first and second tubular members at the overlapping joint there between prior to expanding the first and second tubular members at the area of the joint, according to one aspect of the present invention.

**[0017]** FIG. 8 is a fragmentary cross-sectional schematic illustration of the apparatus of Fig. 7, after the coupled portion of the first and second tubular member wellbore casings and the externally applied tubular sleeve have been radially expanded and plastically deformed according to one aspect of the present invention.

**[0018]** FIG. 9 is a fragmentary cross-sectional schematic illustration of the first female coupling and second male coupling and overlapping tubular sleeve with raised ridges interposed between the couplings to increase the surface to surface contact stress for maintaining sealing contact upon expanding and plastically deforming the coupling and tubular sleeve at the overlapping portions of the first and second tubular members.

**[0019]** Fig. 10 is a fragmentary cross-sectional schematic illustration of an alternative embodiment of the invention in which an interior tubular sleeve 41 is aligned with the coupling joint between tubular members and the interior tubular sleeve 41 is forced outward and applied to the interior surfaces of the tubular members by a magnetic impulse device.

#### **Detailed Description of the Illustrative Embodiments**

**[0020]** Referring to Fig. 1, a borehole 10 that traverses a subterranean formation 12 includes a first tubular member 14, such as a first wellbore casing 14 that is positioned within and coupled to the borehole. In several exemplary embodiments, tubular members in the form of wellbore casings will be described and depicted. It will be understood that although the methods, particularly advantageous for forming wellbore casings, certain advantageous features may also be applicable to other tubular

members as described and claimed herein. In an illustrative embodiment, the first wellbore casing 14 may, for example, be positioned within and coupled to the borehole 10 using any number of conventional methods and apparatus, that may or may not include radial expansion and plastic deformation of the first wellbore casing 14, and/or using one or more of the methods and apparatus disclosed in one or more of the following: (1) U.S. patent application serial no. 09/454,139, attorney docket no. 25791.03.02, filed on 12/3/1999, (2) U.S. patent application serial no. 09/510,913, attorney docket no. 25791.7.02, filed on 2/23/2000, (3) U.S. patent application serial no. 09/502,350, attorney docket no. 25791.8.02, filed on 2/10/2000, (4) U.S. patent no. 6,328,113, (5) U.S. patent application serial no. 09/523,460, attorney docket no. 25791.11.02, filed on 3/10/2000, (6) U.S. patent application serial no. 09/512,895, attorney docket no. 25791.12.02, filed on 2/24/2000, (7) U.S. patent application serial no. 09/511,941, attorney docket no. 25791.16.02, filed on 2/24/2000, (8) U.S. patent application serial no. 09/588,946, attorney docket no. 25791.17.02, filed on 6/7/2000, (9) U.S. patent application serial no. 09/559,122, attorney docket no. 25791.23.02, filed on 4/26/2000, (10) PCT patent application serial no. PCT/US00/18635, attorney docket no. 25791.25.02, filed on 7/9/2000, (11) U.S. provisional patent application serial no. 60/162,671, attorney docket no. 25791.27, filed on 11/1/1999, (12) U.S. provisional patent application serial no. 60/154,047, attorney docket no. 25791.29, filed on 9/16/1999, (13) U.S. provisional patent application serial no. 60/159,082, attorney docket no. 25791.34, filed on 10/12/1999, (14) U.S. provisional patent application serial no. 60/159,039, attorney docket no. 25791.36, filed on 10/12/1999, (15) U.S. provisional patent application serial no. 60/159,033, attorney docket no. 25791.37, filed on 10/12/1999, (16) U.S. provisional patent application serial no. 60/212,359, attorney docket no. 25791.38, filed on 6/19/2000, (17) U.S. provisional patent application serial no. 60/165,228, attorney docket no. 25791.39, filed on 11/12/1999, (18) U.S. provisional patent application serial no. 60/221,443, attorney docket no. 25791.45, filed on 7/28/2000, (19) U.S. provisional patent application serial no. 60/221,645, attorney docket no. 25791.46, filed on 7/28/2000, (20) U.S. provisional patent application serial no. 60/233,638, attorney docket no. 25791.47, filed on 9/18/2000, (21) U.S. provisional patent application serial no. 60/237,334, attorney docket no. 25791.48, filed on 10/2/2000, (22) U.S. provisional patent application serial no. 60/270,007, attorney docket no. 25791.50, filed on 2/20/2001, (23) U.S. provisional patent application serial no. 60/262,434, attorney docket no. 25791.51, filed on 1/17/2001, (24) U.S. provisional patent application serial no. 60/259,486, attorney docket no. 25791.52, filed on 1/3/2001, (25) U.S. provisional patent application serial no. 60/303,740, attorney docket no. 25791.61, filed on 7/6/2001, (26) U.S. provisional patent application serial no. 60/313,453, attorney docket no. 25791.59, filed on 8/20/2001, (27) U.S. provisional patent application serial no. 60/317,985, attorney docket no. 25791.67, filed on 9/6/2001, (28) U.S. provisional patent application serial no. 60/3318,386, attorney docket no. 25791.67.02, filed on 9/10/2001, (29) U.S. utility patent application serial no. 09/969,922, attorney docket no. 25791.69, filed on 10/3/2001, (30) U.S. utility patent

application serial no. 10/016,467, attorney docket no. 25791.70, filed on 12/10/2001; (31) U.S. provisional patent application serial no. 60/343,674, attorney docket no. 25791.68, filed on 12/27/2001; (32) U.S. provisional patent application serial no. 60/346,309, attorney docket no. 25791.92, filed on 1/7/2002; (33) U.S. provisional patent application serial no. 60/372,048, attorney docket no. 25791.93, filed on 4/12/2002; (34) U.S. provisional patent application serial no. 60/380,147, attorney docket no. 25791.104, filed on 5/6/2002; (35) U.S. provisional patent application serial no. 60/387,486, attorney docket no. 25791.107, filed on 6/10/2002; (36) U.S. provisional patent application serial no. 60/387,961, attorney docket no. 25791.108, filed on 6/12/2002; (37) U.S. provisional patent application serial no. 60/391,703, attorney docket no. 25791.90, filed on 6/26/2002; (38) U.S. provisional patent application serial no. 60/397,284, attorney docket no. 25791.106, filed on 7/19/2002, and (39) U.S. provisional patent application serial no. 60/405,394, filed on 8/23/03, the disclosures of which are incorporated herein by reference.

**[0021]** Referring to Fig. 2, the second tubular member 16, such as second wellbore casing 16 is then overlappingly coupled to the first wellbore casing 14 for positioning within the borehole 10. In several exemplary embodiments, the first wellbore casing 14 may, for example, be coupled at a first coupling portion 18 to a second coupling portion 20 of the second wellbore casing 16 using any number of conventional methods and apparatus. For example as shown in Fig. 2, the coupling may comprise a male, or externally, threaded portion 24 engaged with a female, or internally, threaded portion 26. The method of coupling may or may not include radial expansion and plastic deformation of either of the wellbore casings 14 or 16 or both, and or using one of more of the methods disclosed in one of more of the following: (1) U.S. patent application serial no. 09/454,139, attorney docket no. 25791.03.02, filed on 12/3/1999, (2) U.S. patent application serial no. 09/510,913, attorney docket no. 25791.7.02, filed on 2/23/2000, (3) U.S. patent application serial no. 09/502,350, attorney docket no. 25791.8.02, filed on 2/10/2000, (4) U.S. patent no. 6,328,113, (5) U.S. patent application serial no. 09/523,460, attorney docket no. 25791.11.02, filed on 3/10/2000, (6) U.S. patent application serial no. 09/512,895, attorney docket no. 25791.12.02, filed on 2/24/2000, (7) U.S. patent application serial no. 09/511,941, attorney docket no. 25791.16.02, filed on 2/24/2000, (8) U.S. patent application serial no. 09/588,946, attorney docket no. 25791.17.02, filed on 6/7/2000, (9) U.S. patent application serial no. 09/559,122, attorney docket no. 25791.23.02, filed on 4/26/2000, (10) PCT patent application serial no. PCT/US00/18635, attorney docket no. 25791.25.02, filed on 7/9/2000, (11) U.S. provisional patent application serial no. 60/162,671, attorney docket no. 25791.27, filed on 11/1/1999, (12) U.S. provisional patent application serial no. 60/154,047, attorney docket no. 25791.29, filed on 9/16/1999, (13) U.S. provisional patent application serial no. 60/159,082, attorney docket no. 25791.34, filed on 10/12/1999, (14) U.S. provisional patent application serial no. 60/159,039, attorney docket no. 25791.36, filed on 10/12/1999, (15) U.S. provisional patent application serial no. 60/159,033, attorney docket no. 25791.37, filed on 10/12/1999, (16) U.S. provisional patent application serial no.



60/212,359, attorney docket no. 25791.38, filed on 6/19/2000, (17) U.S. provisional patent application serial no. 60/165,228, attorney docket no. 25791.39, filed on 11/12/1999, (18) U.S. provisional patent application serial no. 60/221,443, attorney docket no. 25791.45, filed on 7/28/2000, (19) U.S. provisional patent application serial no. 60/221,645, attorney docket no. 25791.46, filed on 7/28/2000, (20) U.S. provisional patent application serial no. 60/233,638, attorney docket no. 25791.47, filed on 9/18/2000, (21) U.S. provisional patent application serial no. 60/237,334, attorney docket no. 25791.48, filed on 10/2/2000, (22) U.S. provisional patent application serial no. 60/270,007, attorney docket no. 25791.50, filed on 2/20/2001, (23) U.S. provisional patent application serial no. 60/262,434, attorney docket no. 25791.51, filed on 1/17/2001, (24) U.S. provisional patent application serial no. 60/259,486, attorney docket no. 25791.52, filed on 1/3/2001, (25) U.S. provisional patent application serial no. 60/303,740, attorney docket no. 25791.61, filed on 7/6/2001, (26) U.S. provisional patent application serial no. 60/313,453, attorney docket no. 25791.59, filed on 8/20/2001, (27) U.S. provisional patent application serial no. 60/317,985, attorney docket no. 25791.67, filed on 9/6/2001, (28) U.S. provisional patent application serial no. 60/3318,386, attorney docket no. 25791.67.02, filed on 9/10/2001, (29) U.S. utility patent application serial no. 09/969,922, attorney docket no. 25791.69, filed on 10/3/2001, (30) U.S. utility patent application serial no. 10/016,467, attorney docket no. 25791.70, filed on 12/10/2001; (31) U.S. provisional patent application serial no. 60/343,674, attorney docket no. 25791.68, filed on 12/27/2001; (32) U.S. provisional patent application serial no. 60/346,309, attorney docket no. 25791.92, filed on 1/7/2002; (33) U.S. provisional patent application serial no. 60/372,048, attorney docket no. 25791.93, filed on 4/12/2002; (34) U.S. provisional patent application serial no. 60/380,147, attorney docket no. 25791.104, filed on 5/6/2002; (35) U.S. provisional patent application serial no. 60/387,486, attorney docket no. 25791.107, filed on 6/10/2002; (36) U.S. provisional patent application serial no. 60/387,961, attorney docket no. 25791.108, filed on 6/12/2002; (37) U.S. provisional patent application serial no. 60/391,703, attorney docket no. 25791.90, filed on 6/26/2002; (38) U.S. provisional patent application serial no. 60/397,284, attorney docket no. 25791.106, filed on 7/19/2002, and (39) U.S. provisional patent application serial no. 60/405,394, filed on 8/23/03, the disclosures of which are incorporated herein by reference.

**[0022]** Upon coupling the first and second tubular members, such as upon coupling the first and second wellbore casings 14 and 16, as depicted in Fig. 2, a first surface portion 26 and a second surface portion 28 are adjacently positioned in the axial direction and may or may not have the same or nearly the same outside diameters 32 and 34. It would be understood that according to the foregoing methods and apparatus for expanding the wellbore casing, the depiction in Fig. 2 and Fig. 3 may or may not demonstrate an overlapping portion that has been previously expanded. In either instance, it is desirable for the present invention that the exterior first outside diameter 32 and the outside diameter 34 have the same or nearly the same dimensions. For further be seen that a joint 30 is formed there

between that may include a small gap such as a bevel or partial channel on either member as is conventional for accommodating nicks or dents so that they will not interfere with complete coupling between the first and second wellbore casings.

**[0023]** Referring to Fig. 3, it will again be understood that the first wellbore casing 14 and the second wellbore casing 16 may or may not have been radially expanded in the depiction of Fig. 4. A tubular sleeve 40 is positioned overlapping the first surface portion 26 of the first wellbore casings 14 and also overlapping the second surface portion 28 of the second wellbore casing 16, thereby overlapping the joint 30 and axially extending in either direction there from at least partially over the overlapping coupling as well as partially over a portion of casing 16 that does not overlap first wellbore casing 14.

**[0024]** The tubular sleeve 40 is preferably composed of electrically conductive material that are suitably malleable or flowable to be shaped mechanically, as for example copper, aluminum, light metal, and metal alloys. Steel alloys and other metal alloys with suitable electrical conductivity and with suitable malleability or suitable flow behavior may also be used. The inside diameter 42, of the tubular sleeve 40 is only slightly larger than the outside diameter of at the joint 30 the first tubular member 14 or the second tubular member 16. This means a cylindrical gap 44 between the inside surface 46 of sleeve 40 and the first and outside surfaces 26 and 28 of wellbore casings 14 and 16 respectively. The outside diameter 48 of tubular sleeve 40 is slightly larger than the inside diameter 42 defining a thickness 49 that is relatively thin compared the thickness of the wellbore casings 14 and 16.

**[0025]** Fig. 5 is a schematic illustration of the overlapping wellbore casings 14 and 16 and the overlapping tubular sleeve 40, as in Fig. 4, and further schematically depicts a magnetic impulse energy applicator 50. The impulse energy applicator 50, according to one aspect of the present invention, is aligned with the tubular sleeve at a position overlapping the joint 30 and extending a distance over the surfaces 26 and 28 on either side of the joint 30. The magnetic impulse apparatus 50 may comprise an impulse conductor ring 52 having an inside diameter 54 slightly larger than the outside diameter of the ring 40, thereby leaving a small cylindrical gap 56 there between. Conductor ring 52 is interrupted with a radially extending gap (not shown) and is operatively connected to an impulse generator 58 such that the magnetic impulse power flows circumferentially around conductor ring 52 when applied from the impulse generator 58. This method applied to joints of wellbore casing has not heretofore been known, although there are conventional devices and it is a conventional concept for providing a magnetic impulse for shaping of cylindrical metal parts. Thus, the adaptation of one or more of the methods and apparatus according to one or more of the following may be used in connection with this aspect of the present invention: (1) U. S. Patent 5,444,963 issued to Steingroever, et al., August 29, 1995; (2) U. S. Patent 5,586,460 issued to Steingroever December 24, 1996; (3). U. S. Patent 5,953,805 issued to Steingroever September 21, 1999, as well as the techniques an apparatus

is described on the web page of Magnetic-Physics, Inc., with reference to the shaping technique under the trademark Magnetopuls, the disclosures of which are incorporated by reference.

**[0026]** With reference to Fig. 6, the method of applying the tubular sleeve to the joint of wellbore casing 14 and 16 may be more fully understood. The magnetic impulse generator 58 provides a magnetic in pulse to the conductor ring 52. The magnetic impulse causes a powerful magnetic field 60 to be produced and simultaneously causes a counter current magnetic pulse 62 to be produced within tubular sleeve 40. An extremely high concentration of magnetic flux at 64 results in the gap 56 between tubular sleeve 40 and impulse ring 52. This high flux concentration due to the magnetic impulse generates a large force 66 inward from the ring 52 thereby collapsing tubular sleeve 40 onto the surfaces 26 and 28 at the joint. This effectively forms a first sealing interface 70 between the first surface 26 and the inside surface 44 of the tubular sleeve, and also forms a sealing interface 72 between the inside surface 44 of the tubular sleeve and the surface 28 of the second wellbore casing. With sufficiently high force, the malleable or flowable material from which tubular sleeve 40 is made, flows at 74 into the joint gap 30. This method produces a surface to surface air tight metallic seal entirely over the coupling between the first wellbore casing 14 and the second wellbore casing 16. The strength of the tubular sleeve 40 also holds the joint together during the process of mechanical expansion of the wellbore casing at the joint.

**[0027]** In an exemplary embodiment, as illustrated in Figs. 7 and 8, the first and second tubular members, 14 and 16, and the tubular sleeve 40 may then be positioned within another structure 10 such as, for example, a wellbore 10, and radially expanded and plastically deformed, for example, by moving an expansion cone 80 through the interiors of the first and second tubular members 14 and 16. The tapered portions, 76 and 78, of the tubular sleeve 40 as may result from material flow due to large magnetic force of the type of material of sleeve 40 and facilitate the insertion and movement of the first and second tubular members 14 and 16 within and through the structure 10, and the movement of the expansion cone 80 through the interiors of the first and second tubular members, 14 and 16, may be from top to bottom or from bottom to top.

**[0028]** In an exemplary embodiment, during the radial expansion and plastic deformation of the first and second tubular members, 14 and 16, the tubular sleeve 40 is also radially expanded and plastically deformed. In an exemplary embodiment, as a result, the tubular sleeve 40 may be maintained in circumferential tension and the overlapping end coupling portions, 18 and 20, of the first and second tubular members, 14 and 16, may be maintained in circumferential compression.

**[0029]** In FIG. 9, a fragmentary cross-sectional schematic illustration shows an exemplary embodiment of method and apparatus in which first and second tubular members 114 and 116 are overlapping coupled together, as with a first coupling portion 118 and a second coupling portion 120 pressed together in surface-to-surface engagement, and with an overlapping tubular sleeve 40 applied to the exterior thereof and providing a substantially continuous tubular assembly that may be expanded and

plastically deformed. The first coupling portion 118 and the second coupling portion 120 may be overlappingly coupled together, as with a first female coupling portion and a second male coupling portion pushed, slid or pressed together in surface-to-surface engagement, and An overlapping tubular sleeve 40 is applied to the coupling to provide sealing and to stress the tubular coupling portions toward each other. In an exemplary embodiment, one or more raised ridge rings 84(a-c) and corresponding troughs rings 86(a-c) are formed interposed between the first and second couplings to increase the surface to surface contact stress for maintaining sealing contact upon expanding and plastically deforming the coupling and tubular sleeve at the overlapping portions of the first and second tubular members. In this method and apparatus the peaks 88(a-c) of the ridges 84(a-c) have a small area of surface contact with the opposed coupling portion, compared to the entire overlapping coupling area, such that the stress or force per area of contact is significantly increased thereby facilitating the surface to surface seal at the coupling joint. Although the ridge rings 84 are shown formed in the second male coupling portion with the peaks toward the first female male coupling portion, it will be understood based upon this disclosure that the ridge rings 84 might alternatively be formed on the female coupling portion 118 with the peaks toward the female coupling portion 120. The tubular sleeve 40 as applied to the exterior of the overlapping tubular members increases the sealing stress. In a further exemplary embodiment, the tubular sleeve 40 acting together with the raised ridge rings 84 work together to maintain the seal when the tubular members 114 and 116 are expanded and plastically deformed as disclosed herein.

**[0030]** Fig 10 depicts another exemplary embodiment of the invention in which an interior tubular sleeve 41 is aligned with coupling joint between tubular members 14 and 16. Before or after expanding the tubular members the interior tubular sleeve 41 is forced outward by magnetic impulse device 51 in a conventional manner or the adaptation of one of more of the methods and apparatus according to one or more of the following may be used in connection with this aspect of the present invention: (1) U. S. Patent 5,444,963 issued to Steingroever, et al., August 29, 1995; (2) U. S. Patent 5,586,460 issued to Steingroever December 24, 1996; (3) U. S. Patent 5,953,805 issued to Steingroever September 21, 1999, as well as the techniques an apparatus is described on the web page of Magnetic-Physics, Inc., with reference to the shaping technique under the trademark Magnetopuls, the disclosures of which are incorporated by reference. The interior sleeve 41 is applied to the interior surfaces of the tubular members overlapping the coupling joint and thereby facilitates sealing and connection between the tubular members.

**[0031]** As more fully disclosed in US provisional patent application no. 60/405,394, attorney docket 29751.120 filed on 8/23/2002, the disclosure of which is incorporated herein by reference, one or more layers or coatings of softer material, preferably metallic material having a modulus of elasticity lower than the modulus of elasticity of the tubular members at the coupling joint, may be interposed between the joints, to facilitate sealing before and after expanding and plastically deforming joined tubular members such as wellbore casings. The interposed material may also be a material of th type having a lower

melting point before deformation than after deformation. For example the material may be an exothermic material that initially releases energy upon stress or heat input thereby melting or plastically flowing at one temperature and subsequently without the further release of such heat energy having a higher melting point or plastic flow temperature.

**[0032]** In several exemplary embodiments, the first and second tubular members, 14 and 16, are radially expanded and plastically deformed using the expansion cone 80 in a conventional manner and/or using one or more of the methods and apparatus disclosed in one or more of the following: (1) U.S. patent application serial no. 09/454,139, attorney docket no. 25791.03.02, filed on 12/3/1999, (2) U.S. patent application serial no. 09/510,913, attorney docket no. 25791.7.02, filed on 2/23/2000, (3) U.S. patent application serial no. 09/502,350, attorney docket no. 25791.8.02, filed on 2/10/2000, (4) U.S. patent application serial no. 09/440,338, attorney docket no. 25791.9.02, filed on 11/15/1999, (5) U.S. patent application serial no. 09/523,460, attorney docket no. 25791.11.02, filed on 3/10/2000, (6) U.S. patent application serial no. 09/512,895, attorney docket no. 25791.12.02, filed on 2/24/2000, (7) U.S. patent application serial no. 09/511,941, attorney docket no. 25791.16.02, filed on 2/24/2000, (8) U.S. patent application serial no. 09/588,946, attorney docket no. 25791.17.02, filed on 6/7/2000, (9) U.S. patent application serial no. 09/559,122, attorney docket no. 25791.23.02, filed on 4/26/2000, (10) PCT patent application serial no. PCT/US00/18635, attorney docket no. 25791.25.02, filed on 7/9/2000, (11) U.S. provisional patent application serial no. 60/162,671, attorney docket no. 25791.27, filed on 11/1/1999, (12) U.S. provisional patent application serial no. 60/154,047, attorney docket no. 25791.29, filed on 9/16/1999, (13) U.S. provisional patent application serial no. 60/159,082, attorney docket no. 25791.34, filed on 10/12/1999, (14) U.S. provisional patent application serial no. 60/159,039, attorney docket no. 25791.36, filed on 10/12/1999, (15) U.S. provisional patent application serial no. 60/159,033, attorney docket no. 25791.37, filed on 10/12/1999, (16) U.S. provisional patent application serial no. 60/212,359, attorney docket no. 25791.38, filed on 6/19/2000, (17) U.S. provisional patent application serial no. 60/165,228, attorney docket no. 25791.39, filed on 11/12/1999, (18) U.S. provisional patent application serial no. 60/221,443, attorney docket no. 25791.45, filed on 7/28/2000, (19) U.S. provisional patent application serial no. 60/221,645, attorney docket no. 25791.46, filed on 7/28/2000, (20) U.S. provisional patent application serial no. 60/233,638, attorney docket no. 25791.47, filed on 9/18/2000, (21) U.S. provisional patent application serial no. 60/237,334, attorney docket no. 25791.48, filed on 10/2/2000, (22) U.S. provisional patent application serial no. 60/270,007, attorney docket no. 25791.50, filed on 2/20/2001, (23) U.S. provisional patent application serial no. 60/262,434, attorney docket no. 25791.51, filed on 1/17/2001, (24) U.S. provisional patent application serial no. 60/259,486, attorney docket no. 25791.52, filed on 1/3/2001, (25) U.S. provisional patent application serial no. 60/303,740, attorney docket no. 25791.61, filed on 7/6/2001, (26) U.S. provisional patent application serial no. 60/313,453, attorney docket no. 25791.59, filed on 8/20/2001, (27) U.S. provisional patent application serial no. 60/317,985, attorney docket no. 25791.67, filed on 9/6/2001, (28) U.S. provisional patent application serial no.

60/3318,386, attorney docket no. 25791.67.02, filed on 9/10/2001, (29) U.S. utility patent application serial no. 09/969,922, attorney docket no. 25791.69, filed on 10/3/2001, (30) U.S. utility patent application serial no. 10/016,467, attorney docket no. 25791.70, filed on 12/10/2001; (31) U.S. provisional patent application serial no. 60/343,674, attorney docket no. 25791.68, filed on 12/27/2001; (32) U.S. provisional patent application serial no. 60/346,309, attorney docket no. 25791.92, filed on 1/7/2002; (33) U.S. provisional patent application serial no. 60/372,048, attorney docket no. 25791.93, filed on 4/12/2002; (34) U.S. provisional patent application serial no. 60/380,147, attorney docket no. 25791.104, filed on 5/6/2002; (35) U.S. provisional patent application serial no. 60/387,486, attorney docket no. 25791.107, filed on 6/10/2002; (36) U.S. provisional patent application serial no. 60/387,961, attorney docket no. 25791.108, filed on 6/12/2002; (37) U.S. provisional patent application serial no. 60/391,703, attorney docket no. 25791.90, filed on 6/26/2002; (38) U.S. provisional patent application serial no. 60/397,284, attorney docket no. 25791.106, filed on 7/19/2002, and (39) U.S. provisional patent application serial no. 60/405,394, filed on 8/23/03, the disclosures of which are incorporated herein by reference.

**[0033]** In several alternative embodiments, the first and second tubular members, 14 and 16, are radially expanded and plastically deformed using other conventional methods for radially expanding and plastically deforming tubular members such as, for example, internal pressurization and/or roller expansion devices such as, for example, that disclosed in U.S. patent application publication no. US 2001/0045284 A1, the disclosure of which is incorporated herein by reference.

**[0034]** The use of the tubular sleeve 40 during (a) the coupling of the first tubular member 19 to the second tubular member 16, (b) the placement of the first and second tubular members in the structure 10, (c) the radial expansion and plastic deformation of the first and second tubular members, and (d) magnetic impulse applying tubular sleeve to the overlapping coupling ends between the first and second tubular members provides a number of significant benefits. For example, the tubular sleeve 40 protects the exterior surfaces of the end portions, 18 and 20, of the first and second tubular members, 14 and 16, during handling and insertion of the tubular members within the structure 10. In this manner, damage to the exterior surfaces of the end portions, 18 and 20, of the first and second tubular member, 14 and 16, are prevented that could result in stress concentrations that could result in a catastrophic failure during subsequent radial expansion operations. Furthermore, the tubular sleeve 40 provides an alignment guide that facilitates the insertion and threaded coupling of the second tubular member 16 to the first tubular member 14. In this manner, misalignment that could result in damage to the threaded connections, 22 and 24, of the first and second tubular members, 14 and 16, may be avoided. In addition, during the relative rotation of the second tubular member with respect to the first tubular member, required during the threaded coupling of the first and second tubular members, the tubular sleeve 40 provides an indication of to what degree the first and second tubular members are threadably coupled. For example, if the tubular sleeve 40 can be easily rotated, that would indicate that the first and second tubular members, 14 and 16, are not fully threadably coupled

and in intimate contact with the internal flange 36 of the tubular sleeve. Furthermore, the tubular sleeve 16 may prevent crack propagation during the radial expansion and plastic deformation of the first and second tubular members, 14 and 16. In this manner, failure modes such as, for example, longitudinal cracks in the end portions, 18 and 20, of the first and second tubular members may be limited in severity or eliminated all together. In addition, after completing the radial expansion and plastic deformation of the first and second tubular members, 14 and 16, the tubular sleeve 40 may provide a fluid tight metal-to-metal seal between interior surface of the tubular sleeve and the exterior surfaces of the end portions, 18 and 20, of the first and second tubular members. In this manner, fluidic materials are prevented from passing through the threaded connections, 22 and 24, of the first and second tubular members, 14 and 16, into the annulus between the first and second tubular members and the structure 10. Furthermore, because, following the radial expansion and plastic deformation of the first and second tubular members, 14 and 16, the tubular sleeve 40 may be maintained in circumferential tension and the end portions, 18 and 20, of the first and second tubular members, 14 and 16, may be maintained in circumferential compression, axial loads and/or torque loads may be transmitted through the tubular sleeve. In addition, the tubular sleeve 40 may also increase the collapse strength of the end portions, 18 and 20, of the first and second tubular members, 14 and 16.

**[0035]** A useful method of forming a wellbore casing within a borehole that traverses a subterranean formation has been described that includes a first wellbore casing for positioning within the borehole and coupling the first wellbore casing to the borehole, positioning a second wellbore casing within the borehole such that the second wellbore casing overlaps with and is coupled to a portion of the first wellbore casing thereby forming a joint, positioning a tubular sleeve so that it overlaps with and is coupled to at least a portion of the first wellbore casing and to a portion of the second wellbore casing, the tubular sleeve extending a length in either axial direction from the joint between the first and second wellbore casings, causing the tubular sleeve to collapse inwardly onto the respective end portions of the first and second wellbore casings and to sealingly engage the exterior surfaces of the end portions of the first and second wellbore casings respectively on either side of the joint there between, thereby facilitating sealing the joint.

**[0036]** In an exemplary embodiment, the method further includes regularly expanding and plastically deforming the overlapping portions of the first and second wellbore casing and regularly expanding and plastically deforming the tubular sleeve that was sealingly collapsed onto the overlapping portions of the first and second wellbore casings. In an exemplary embodiment, the exterior diameters of the first and second wellbore casings axially adjacent to the joint there between are substantially equal. In an exemplary embodiment, the inside diameters of the first wellbore casings and the inside diameter of the second wellbore casing are substantially equal. In an exemplary

embodiment, the inside diameters of the first wellbore casing and the second wellbore casing are substantially constant.

**[0037]** It will further understood by those skilled in the art upon reading the foregoing disclosure and the claims that follow, and upon review of the drawings that the method may further include forming a wellbore casing within a borehole that traverses a subterranean formation including positioning first wellbore casing, second wellbore casing and additional wellbore casings within the borehole that overlaps one with the other and that are coupled to one another at a joint between each successive wellbore casing. In the method with additional wellbore casings would further includes additional tubular sleeves positioned to overlap each successive joint of the successive wellbore casings in causing each sleeve to collapse inwardly on the respective end portions of the first, second, and additional wellbore casings to sealingly engage the exterior surfaces of the respective end portions. The method further includes the use of magnetic impulse energy to collapse the tubular sleeves onto the surfaces of the wellbore casings at the joints thereof, thereby facilitating sealing of the joints.

**[0038]** It is understood that variations may be made in the foregoing without departing from the scope of the invention. For example, the teachings of the present illustrative embodiments may be used to provide a wellbore casing, a pipeline, or a structural support. Furthermore, the elements and teachings of the various illustrative embodiments may be combined in whole or in part in some or all of the illustrative embodiments.

**[0039]** Although illustrative embodiments of the invention have been shown and described, a wide range of modification, changes and substitution is contemplated in the foregoing disclosure. In some instances, some features of the present invention may be employed without a corresponding use of the other features. Accordingly, it is appropriate that the appended claims be construed broadly and in a manner consistent with the scope of the invention.



**Claims**

What is claimed is:

1. A method of forming a wellbore casing within a borehole that traverses a subterranean formation, comprising:
  - assembling a tubular liner by a process comprising:
    - coupling a threaded portion of a first tubular member to the threaded portion of a second tubular member; and
    - coupling a tubular sleeve to the threaded portions of the first and second tubular members;
  - positioning the tubular liner assembly within the borehole; and
  - radially expanding and plastically deforming the tubular liner assembly within the borehole; wherein coupling the tubular sleeve to the threaded portions of the first and second tubular members comprises:
    - applying impulsive magnetic energy to the tubular sleeve.
  
2. A method of forming a coupling between metallic tubular members comprising a process comprising the steps of:
  - forming a female coupling portion on a first tubular member;
  - forming a male coupling portion on a second tubular member;
  - forming at least one raised ridge ring between the male and female coupling portions;
  - coupling the female coupling portion of the first tubular member and the male portion of the second tubular member including pressing the coupling portions together in surface-to-surface contact;
  - applying a tubular sleeve to exterior surfaces of the pressed together coupling portions of the first and second tubular members using a magnetic impulse generator; and
  - radially expanding and plastically deforming the coupling between the tubular members with the tubular sleeve applied.
  
3. The process as in claim 2 wherein the step of coupling the male and female coupling portions together further comprises the step of forming at least one ridge ring interposed between the coupling portions to increase the surface-to-surface stress, thereby facilitating sealing between the first and second tubular members.

4. The process as in claim 2 wherein the step of coupling the male and female coupling portions together further comprises the step of forming a layer of material softer than the metallic tubular members interposed between the coupling portions to increase the surface-to-surface stress, thereby facilitating sealing between the first and second tubular members.

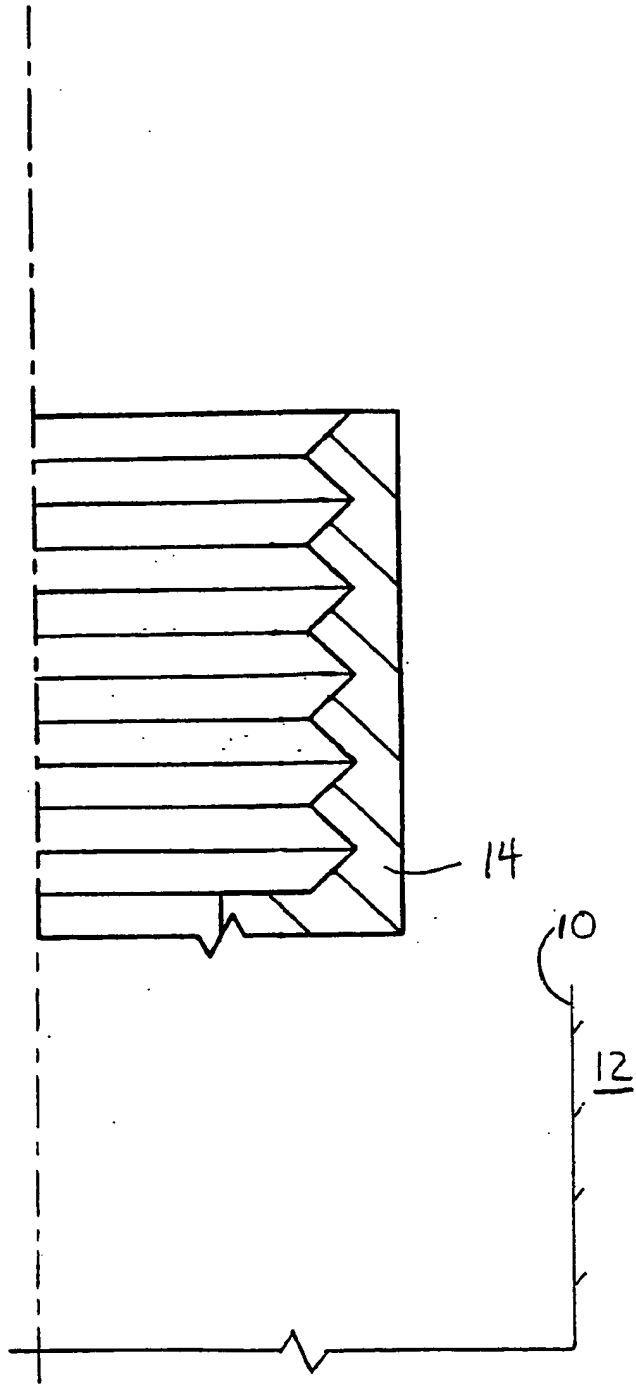

Fig. 1

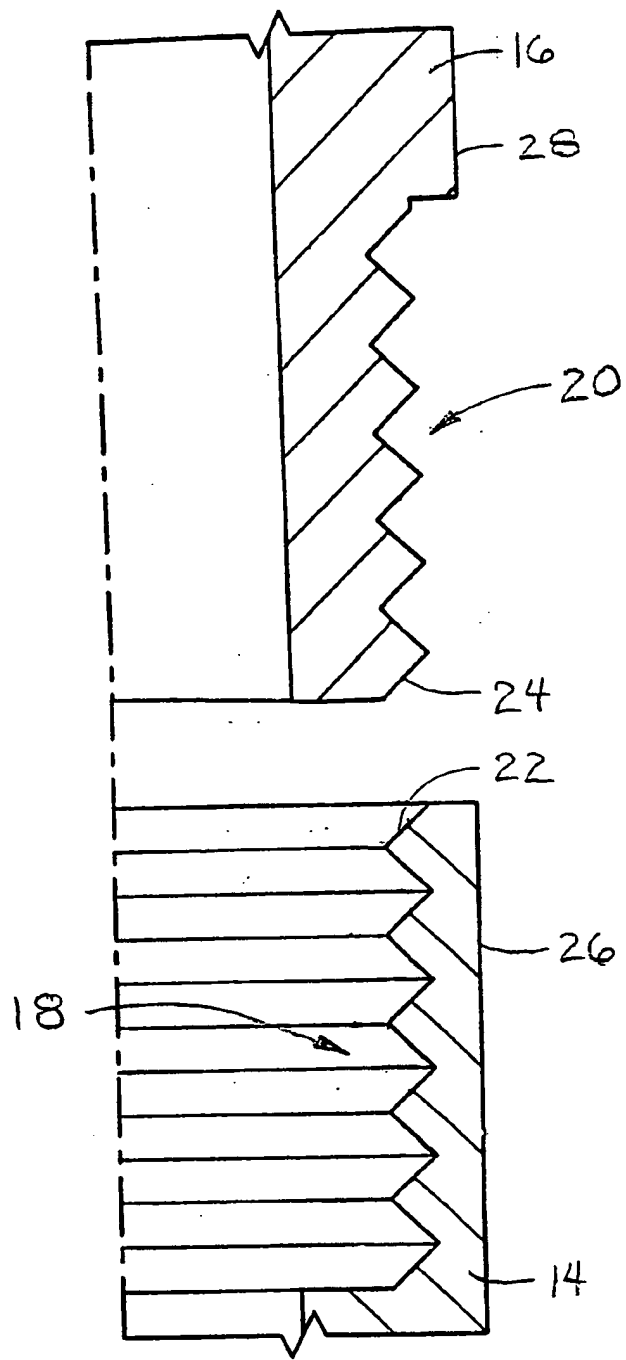

Fig. 2

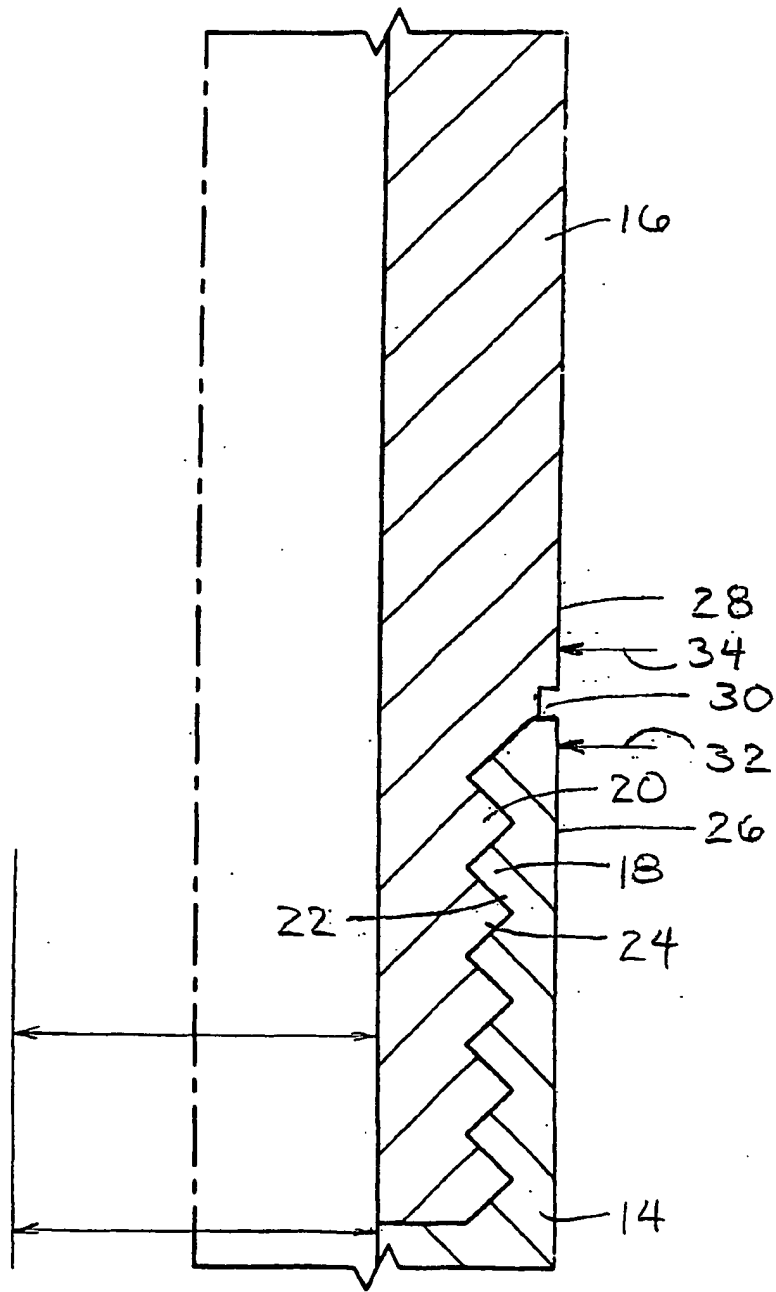

Fig. 3

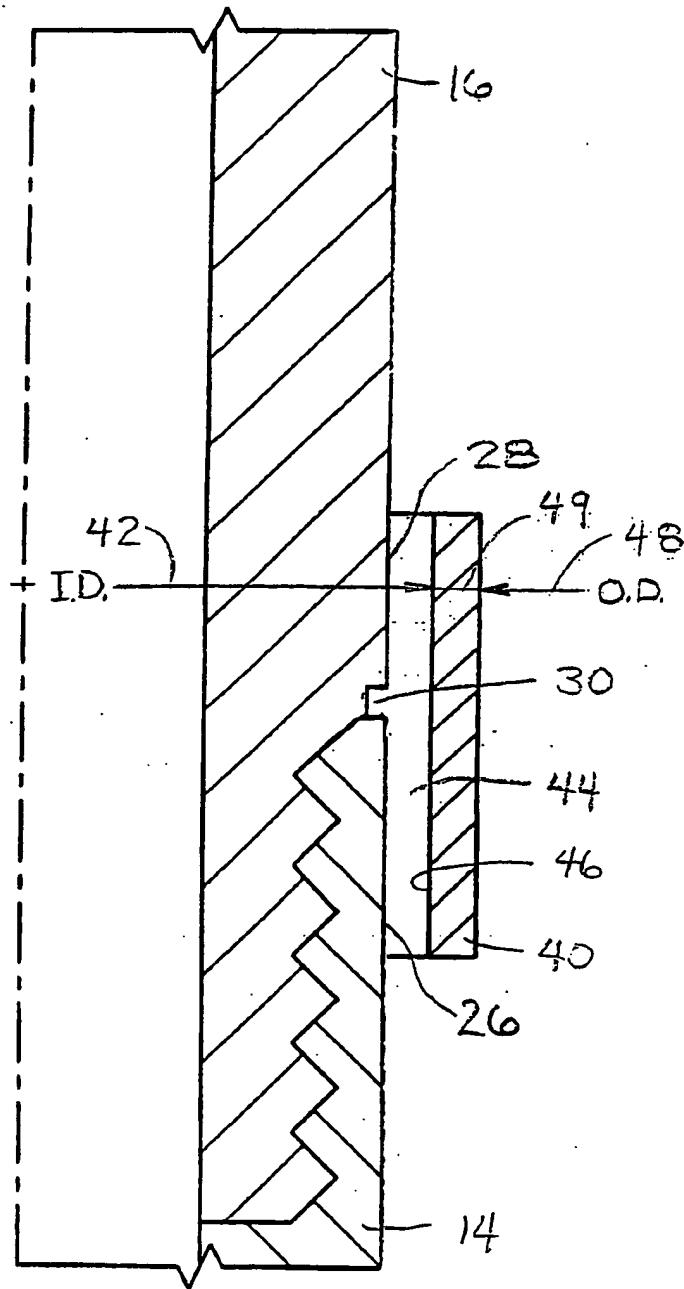

Fig. 4

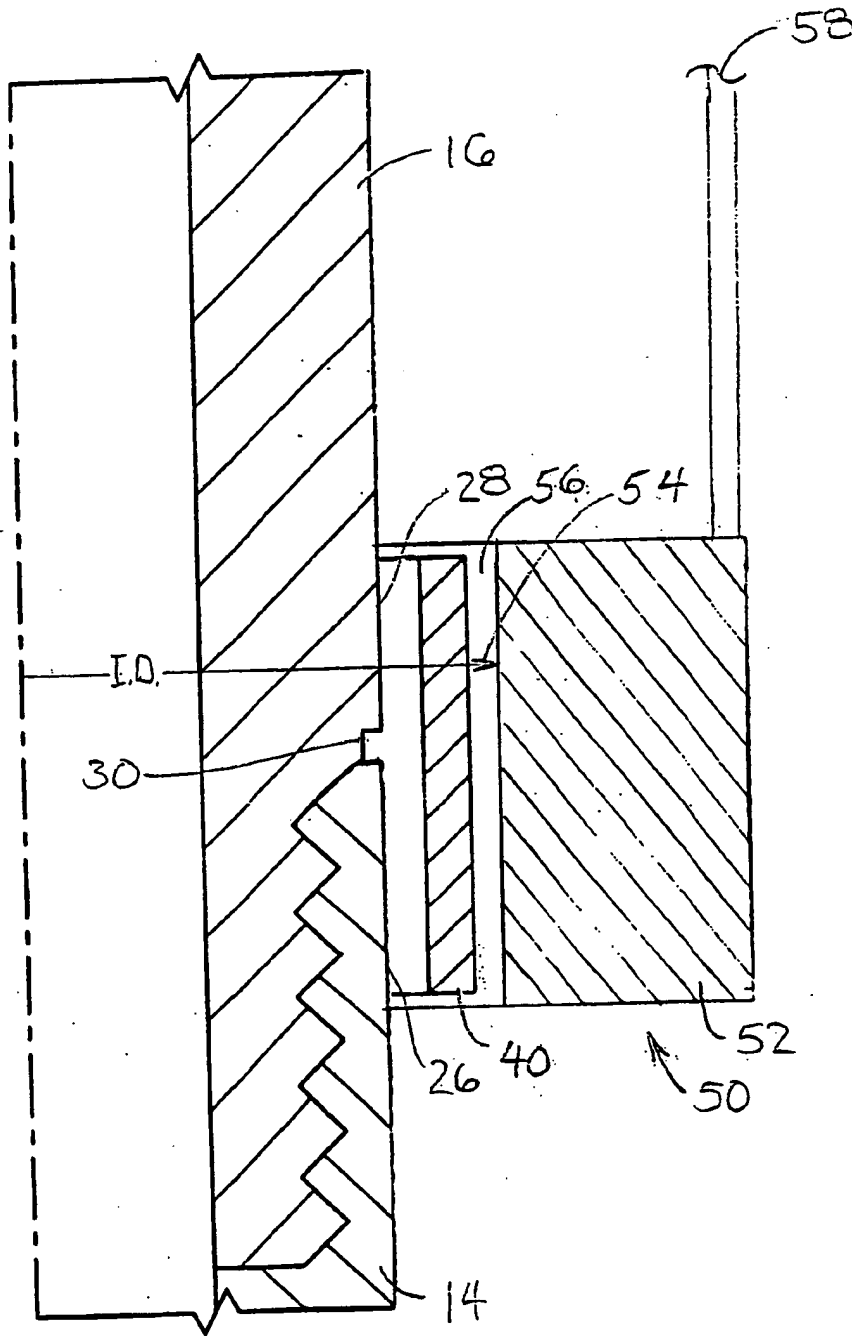

Fig. 5

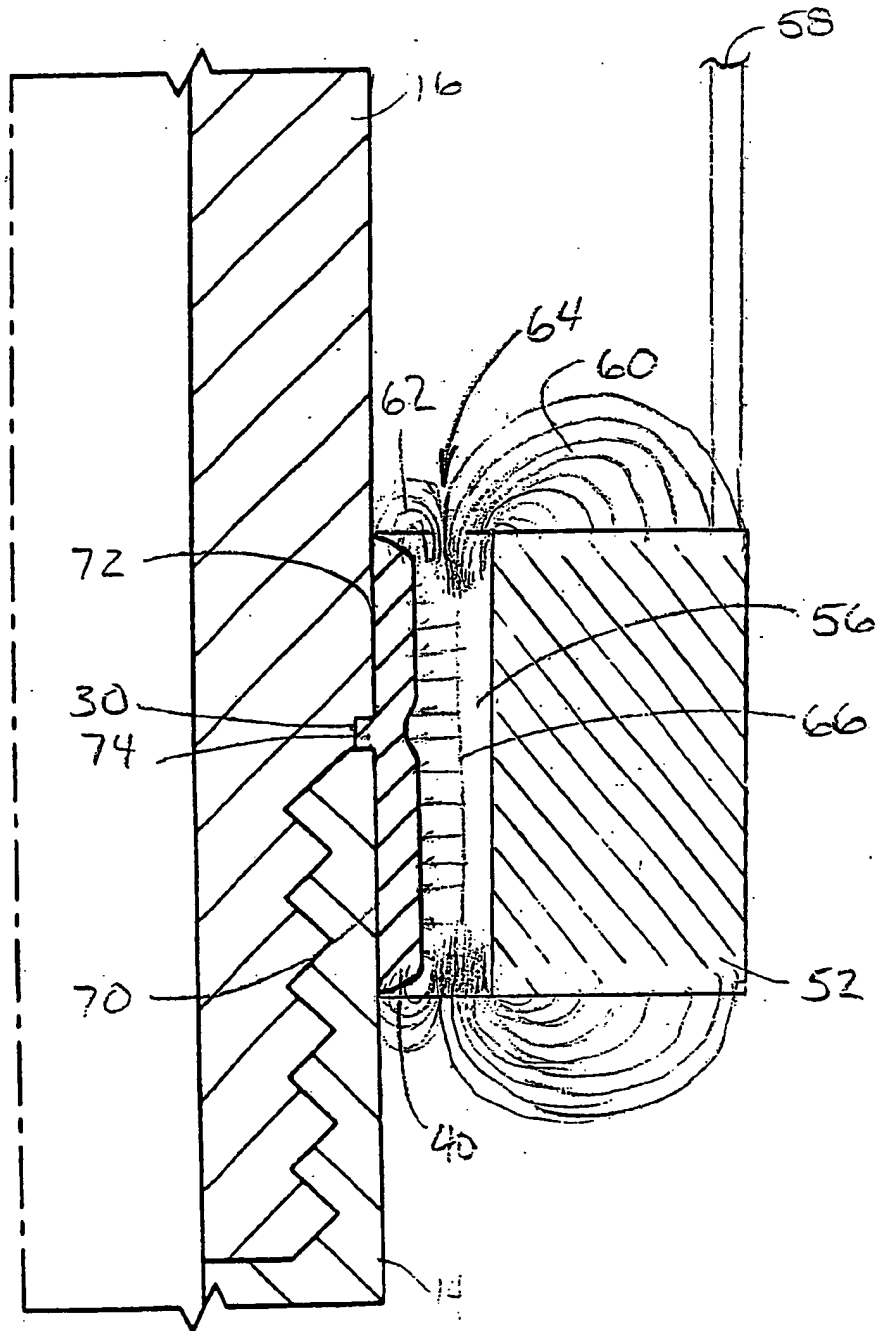

Fig. 6



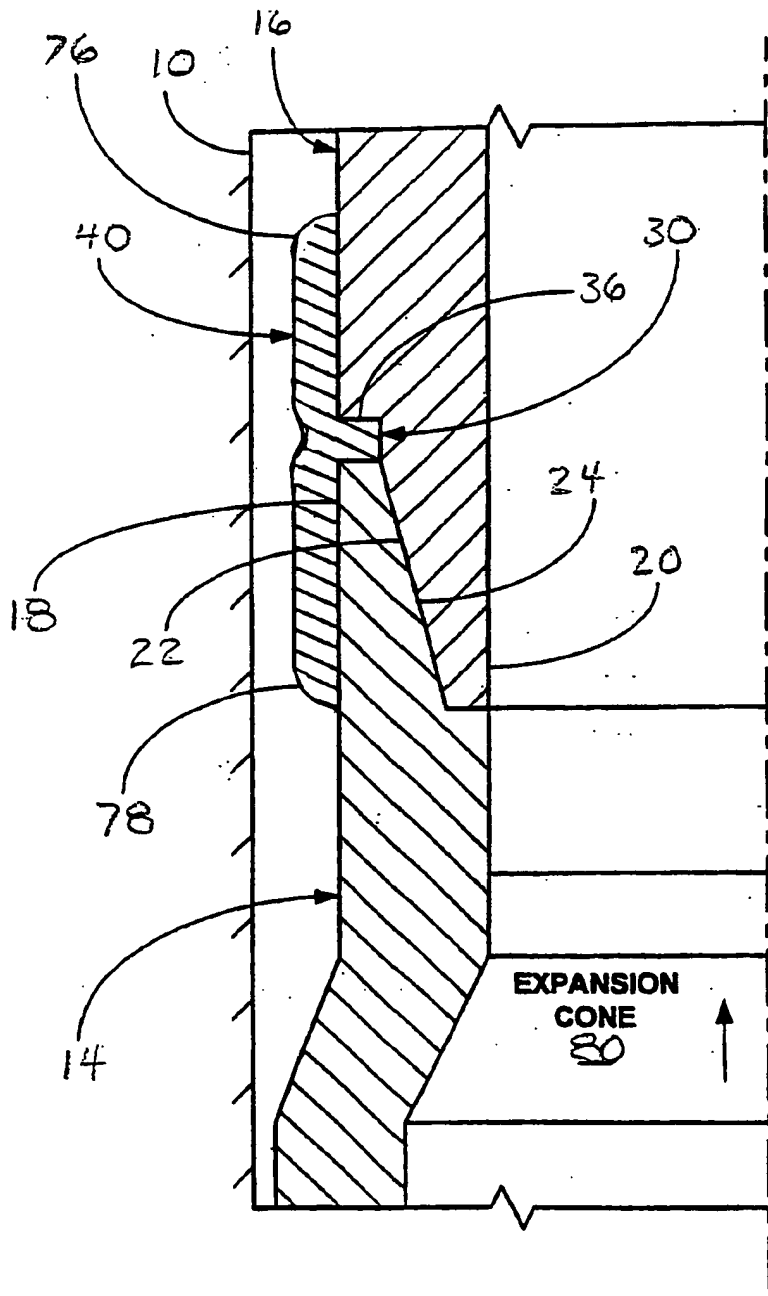

Fig. 7

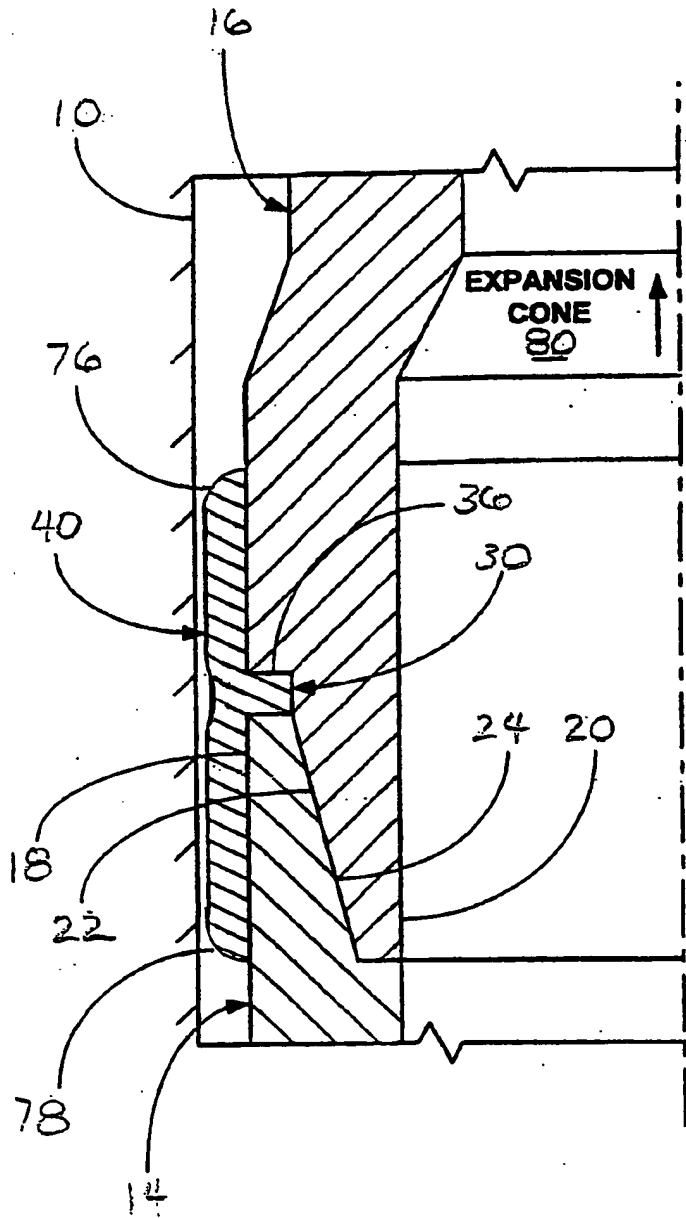

Fig. 8

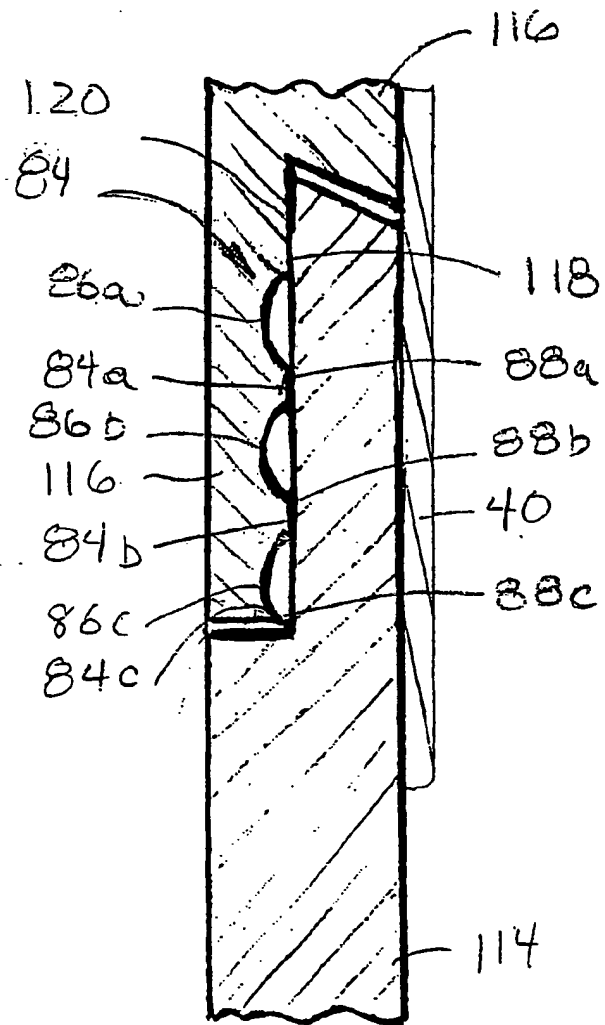

Fig. 9

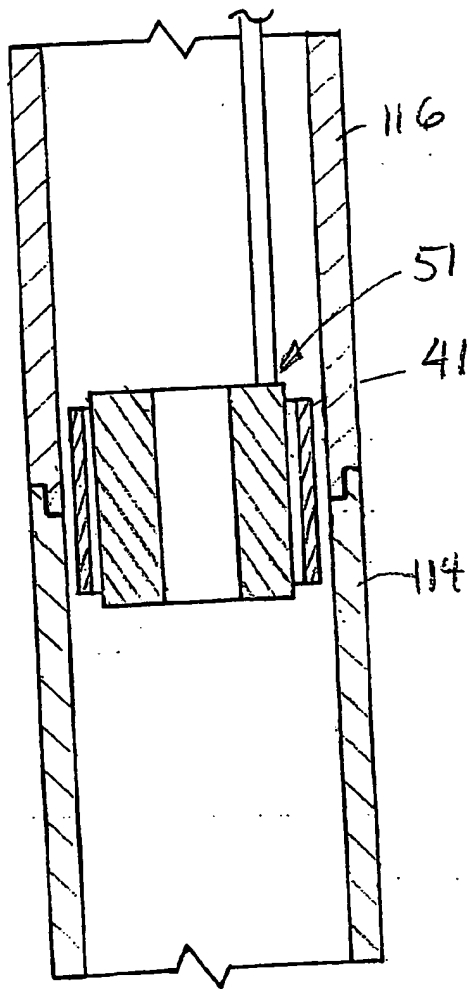

FIG. 10